



BOOSTER PUMPS  
ECOTRONIC  
INOXTRONIC  
ECOMATIC



# ECOTRONIC



## ECOTRONIC BOOSTER SETS

### Applications

High reliable electronic booster sets for supplying water for domestic applications. Built with an electronic safety device that automatically Start and Stop the pump when taps are opened or closed and also protects the pump from dry-running which has a Built-in non return valve. These type of systems give a Constant pressure at a constant flow rate and so are excelent for domestic irrigation systems

- \* Pressure Boosting
- \* Residential Homes
- \* Farming Applications
- \* Resedential Irrigation
- \* Garden Irrigation Drip/Low Flow
- \* Hydroponics
- \* Rain Water Harvesting
- \* Water Supply from Shallow Wells

## TECHNICAL DATA

### CONSTRUCTION

- Plug & Play
- Anti-corrosive and rust-proof materials
- Motor with thermic overload protection
- Wear resistant shaft and impeller
- Equipped with an electronic safety device that protects the pump from dry-running
- Built-in non return valve
- Designed to automatically Start and Stop the pump when taps are opened or closed
- Automatic and manual reset
- Constant pressure and flow rate
- Supplied with power cable with plug
- The "F" version is supplied with an inline filter

# ECOTRONIC HYDRAULIC DATA

## TECHNICAL DATA

Model	HP	Watts	Volts	Frequency	Amps	Maxsuction Depth	MaxFlow	Max Head	Suction	Discharge
ECOTRONIC 110	1/2	800	115	60 Hz	8	29 ft	16 gpm	138 ft	1" NPT	1" NPT
ECOTRONIC 120 F	3/4	1000	115	60 Hz	10		16 gpm	164 ft		
ECOTRONIC 130	1	1250	115	60 Hz	13		21 gpm	164 ft		
ECOTRONIC 230	1/2	800	115	60 Hz	7.5	29 ft	27 gpm	118 ft	1" NPT	1" NPT
ECOTRONIC 240 F	3/4	1000	115	60 Hz	10		27 gpm	157 ft		
ECOTRONIC 250	1	1250	115	60 Hz	13		27 gpm	197 ft		

## TECHNICAL DATA

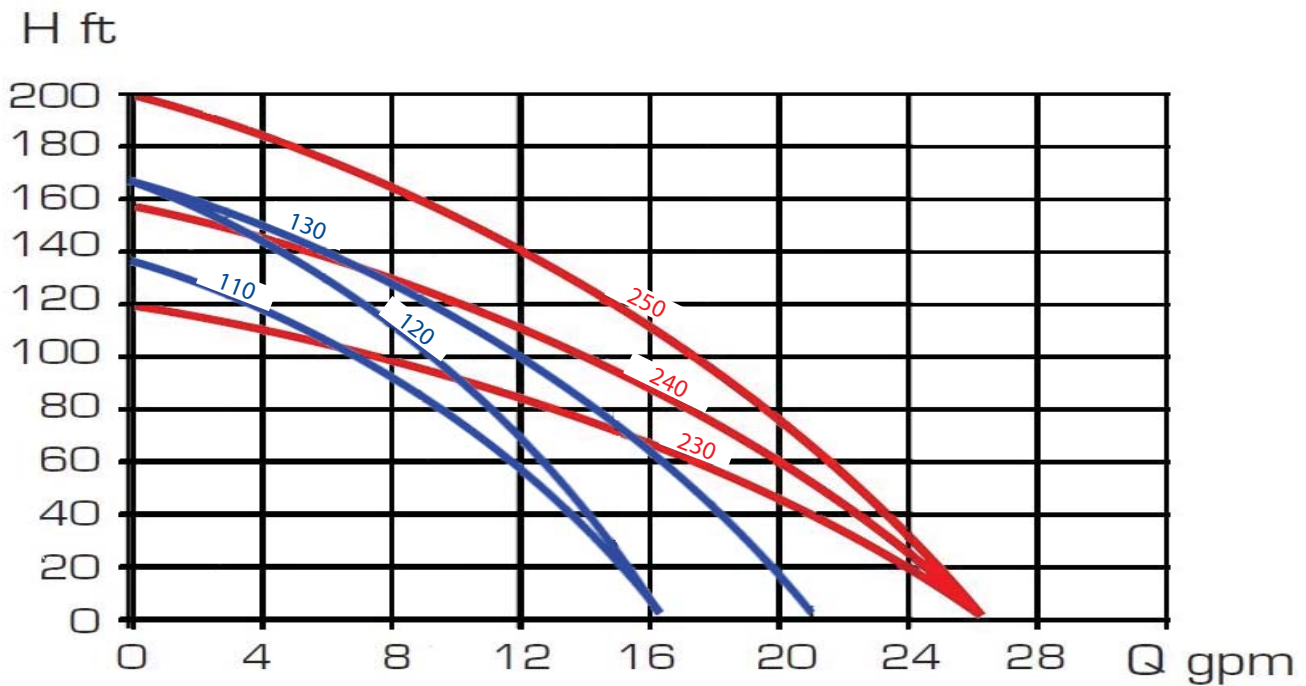

## DIMENSIONS

Model	Lenght	Depth	Height	Weight	Pallet Qty
ECOTRONIC 110	16.3"	9.3"	15"	19 lbs	28
ECOTRONIC 120 F	16.3"	9.3"	15"	24 lbs	
ECOTRONIC 130	16.3"	9.3"	15"	27 lbs	
ECOTRONIC 230	14.6"	9.1"	15.2"	21 lbs	
ECOTRONIC 240 F	15.4"	9.1"	15.2"	26 lbs	
ECOTROINC 250	16.5"	9.1"	15.2"	29 lbs	

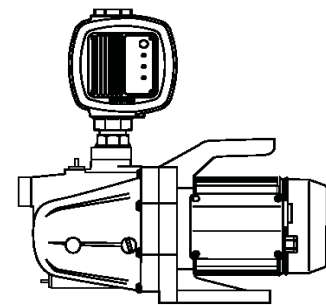

l x d x h

# INOXTRONIC



## INOXTRONIC BOOSTER SETS

### Applications

High reliable electronic booster sets for supplying water for domestic applications.

Built with an electronics safety device that automatically Start and Stop the pump when taps are opened or closed and also protects the pump from dry-running which has a Built-in non return valve. These type of systems give a Constant pressure at a constant flow rate and so are excelent for domestic irrigation systems

- \* Pressure Boosting
- \* Residential Homes
- \* Farming Applications
- \* Resedential Irrigation
- \* Garden Irrigation Drip/Low Flow
- \* Hydroponics
- \* Rain Water Harvesting
- \* Water Supply from Shallow Wells

## TECHNICAL DATA

### CONSTRUCTION

- Plug & Play
- Anti-corrosive and rust-proof materials
- Motor with thermic overload protection
- Wear resistant shaft and impeller
- Equipped with an electronic safety device that protects the pump from dry-running
- Built-in non return valve
- Designed to automatically Start and Stop the pump when taps are opened or closed
- Automatic and manual reset
- Constant pressure and flow rate
- Supplied with power cable with plug

# INOXTRONIC HYDRAULIC DATA

## TECHNICAL DATA

Model	HP	Watts	Volts	Frequency	Amps	Minsuction Depth	MaxFlow	Max Head	Suction	Dis-charge
INOXTRONIC 230	1/2	800	115	60 Hz	7.5	26 ft	27 gpm	120 ft	1"	1"
INOXTRONIC 240	3/4	1000	115	60 Hz	10		27 gpm	158 ft		
INOXTRONIC 250	1	1250	115	60 Hz	13		27 gpm	200 ft		

## TECHNICAL DATA

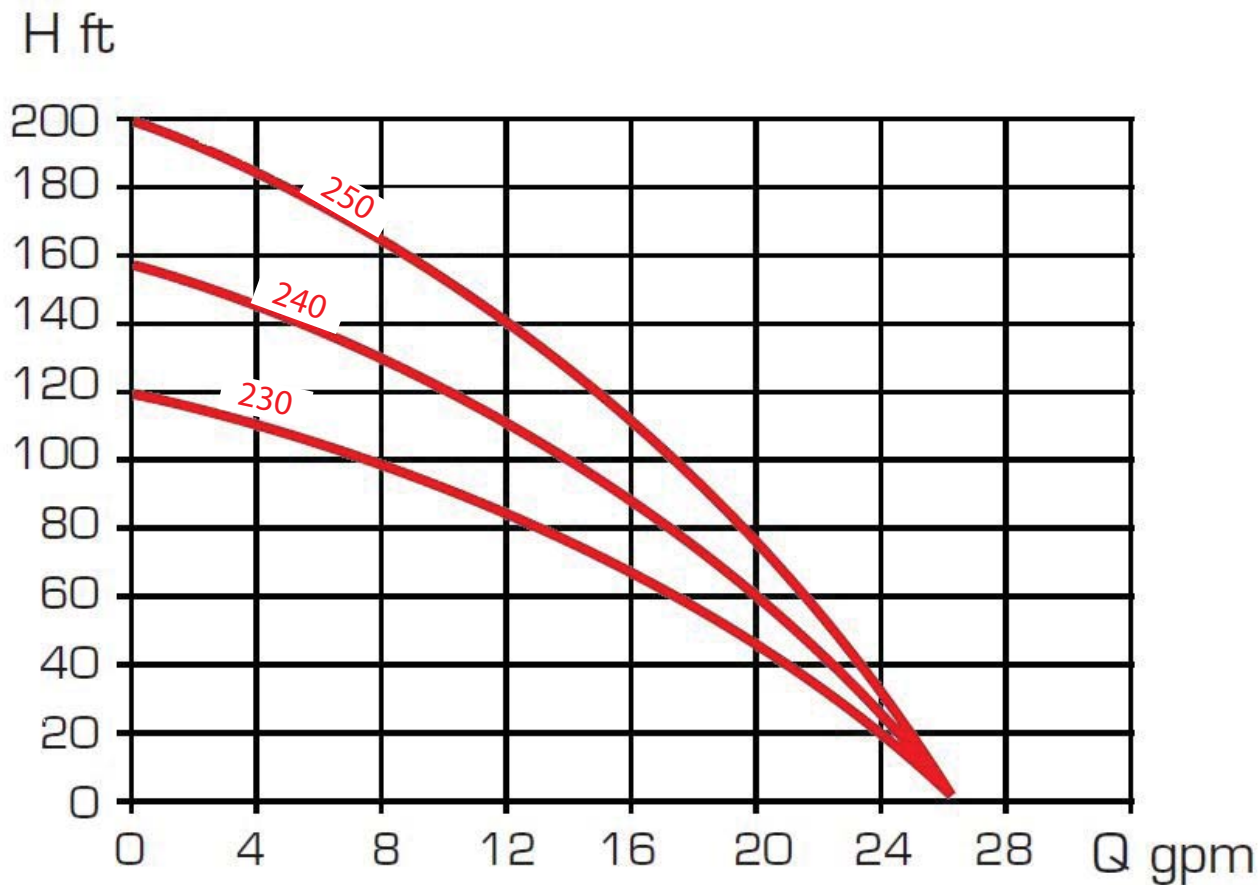

## DIMENSIONS

Model	Length	Depth	Height	Weight	PalletQty
INOXTRONIC230	14.6"	9.1"	15.2"	21 lbs	28
INOXTRONIC240	15.4"	9.1"	15.2"	25 lbs	
INOXTRONIC250	16.5"	9.1"	15.2"	29 lbs	

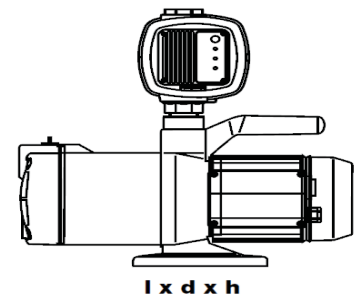

l x d x h

# ECOMATIC



## ECOMATIC BOOSTER SETS

### Applications

High reliable electromechanical booster sets for supplying water for domestic applications.

Built with a gauge and a fully adjustable pressure switch that will automatically Start and Stop the pump when taps are opened or closed. This type of system is still the most common type of system used for pressure boosting

- \* Pressure Boosting
- \* Residential Homes
- \* Farming Applications
- \* Residential Irrigation
- \* Garden Irrigation Drip/Low Flow
- \* Hydroponics
- \* Rain Water Harvesting
- \* Water Supply from Shallow Wells

## TECHNICAL DATA

### CONSTRUCTION

- Anti-corrosive and rust-proof materials
- Motor with thermic overload protection
- Wear resistant shaft and impeller
- Excellent cooling of the motor that enables the pump to operate even when it is partially submerged
- Automatic version with start/ stop float switch and Manual version
- Supplied with power cable with plug and self-sealing fitting

# ECOMATIC HYDRAULIC DATA

## TECHNICAL DATA

Model	HP	Watts	Volts	Frequency	Amps	Max suction depth	Max Flow	Max Head	Suction	Discharge
ECOMATIC 110	1/2	800	115	60 Hz	8	29 ft	16 gpm	135 ft	1" NPT	1" NPT
ECOMATIC 120 F	3/4	1000	115	60 Hz	10		16 gpm	164 ft		

## TECHNICAL DATA

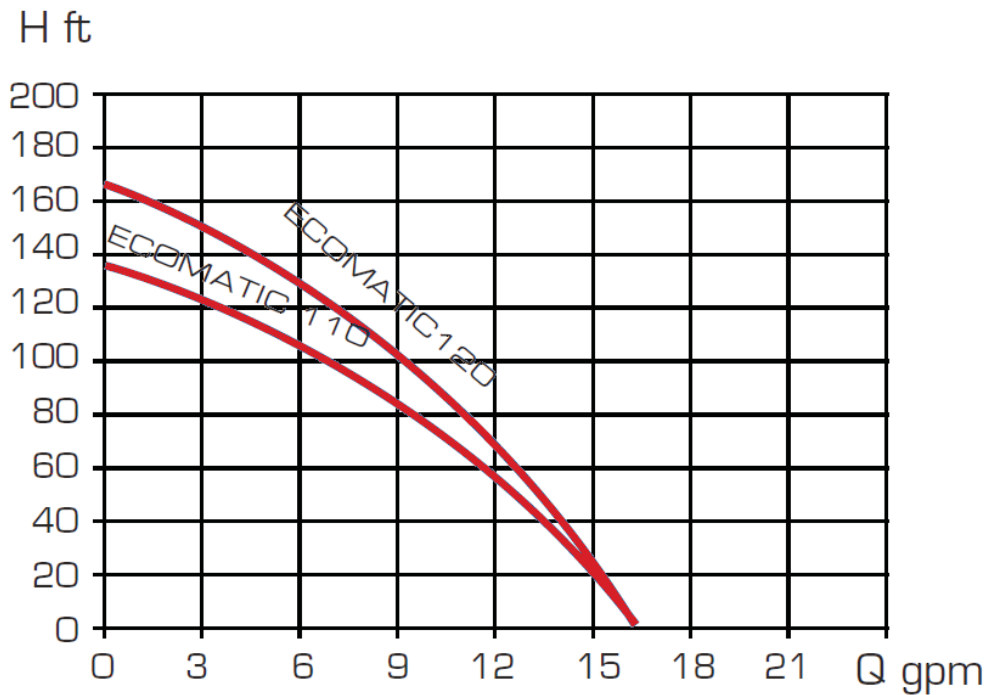

## DIMENSIONS

Model	ECOMATIC 110	ECOMATIC 120 F
LENGTH	10.4"	11.4"
DEPTH	10.4"	11.4"
WIDTH	5.5"	5.5"
WEIGHT	4.8 lbs	6 lbs
PALLET QTY	28	28
TANK SIZE	4 Gallon	4 Gallon
MAX PRESS	100 psi	100 psi
FILTER Incl.	No	YES

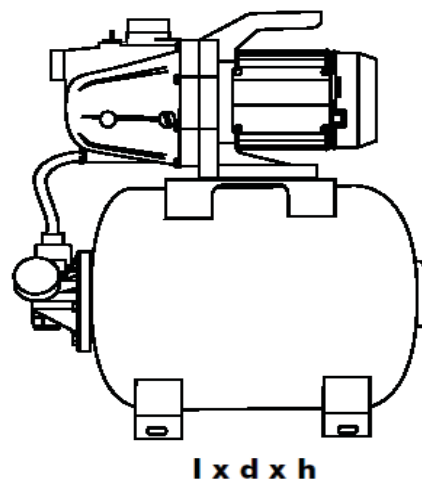

 **DAB PUMPS LTD.**  
Unit 4, Stortford Hall Industrial  
Park Dunmow Road, Bishops Stortford, Herts  
CM23 5GZ - UK  
[info.uk&eire@dwtgroup.com](mailto:info.uk&eire@dwtgroup.com)  
Tel.: +44 1279 652 776  
Fax: +44 1279 657 727

 **DAB PUMPS B.V.**  
Albert Einsteinweg, 4  
5151 DL Drunen - Nederland  
[info.netherlands@dwtgroup.com](mailto:info.netherlands@dwtgroup.com)  
Tel.: +31 416 387280  
Fax: +31 416 387299

 **DAB PUMPS B.V.**  
Brusselstraat 150  
B-1702 Groot-Bijgaarden - Belgium  
[info.belgium@dwtgroup.com](mailto:info.belgium@dwtgroup.com)  
Tel.: +32 2 4668353  
Fax: +32 2 4669218

 **DAB PUMPEN DEUTSCHLAND GmbH**  
Tackweg 11  
D - 47918 Tönisvorst - Germany  
[info.germany@dwtgroup.com](mailto:info.germany@dwtgroup.com)  
Tel.: +49 2151 82136-0  
Fax: +49 2151 82136-36

 **DAB PUMPS INC.**  
3226 Benchmark Drive  
Ladson, SC 29456 USA  
[info.usa@dwtgroup.com](mailto:info.usa@dwtgroup.com)  
Ph. : 1-843-797-5002  
Fax : 1-843-797-3366

 **DAB PUMPS IBERICA S.L.**  
Parque Empresarial San Fernando  
Edificio Italia Planta 1ª  
28830 - San Fernando De Henares - Madrid  
Spain  
[info.spain@dwtgroup.com](mailto:info.spain@dwtgroup.com)  
Ph.: +34 91 6569545  
Fax: +34 91 6569676

 **DWT GROUP Russia**  
100 bldg. 3 Dmitrovskoe highway,  
127247 Moscow - Russia  
[info.russia@dwtgroup.com](mailto:info.russia@dwtgroup.com)  
Tel.: +7 495 739 52 50  
Fax: +7 495 485-3618

 **DAB PUMPS CHINA**  
Shandong Sheng Qingdao Shi  
Jinji Jishu Kaifagu Kaituo Rd  
ZIP PC266510  
CN - China  
[info.china@dwtgroup.com](mailto:info.china@dwtgroup.com)  
Tel.: +8613608963089  
Fax: +8653286812210